

5kW All-in-one the Hybrid Inverter User Manual

Important Notice







In order to protect the legitimate rights and interests of users, please read our operating procedures and safety instructions carefully before using this equipment. Please operate the equipment according to the operating procedures and safety instructions.

Once using this device, you are deemed to have read, understood, endorsed and accepted all terms and contents of the device's operating procedures and safety instructions. The User is committed to being responsible for his or her actions and all consequences arising therefrom.



The User undertakes to use the device solely for legitimate purposes and agrees to these Terms and any relevant national policies or guidelines.

In using this equipment, please strictly observe and implement the requirements including but not limited to the operating procedures and safety instructions. All personal injury, accident, property damage, legal disputes and other adverse events that cause conflicts of interest caused by violations of the user instructions or force majeure indicated by the safety instructions are the responsibility and loss of the User. Our company will not assume any responsibility.

Copyright, all rights reserved. The content is subject to change without notice.

	Caution! Failure to observe a warning indicated in this manual may result in injury.
	The danger of high voltage and electric shock!
	Refer to the operating instructions
	Signals danger due to electrical shock and indicates the time(5 minutes)to allow after the inverter has been turned off and disconnected to ensure safety in any installation operation.
	The danger of hot surface!
	Protective earth

Installation Risk Notification

 Warning	Wear protective gloves when handling equipment by hand to prevent cuts from sharp objects.
 Attention	Make sure the cable label is correct before connecting the cable.
 Dangerous	Construction operation of high-voltage lines may cause fire or electric shock. The area through which the AC cable is connected and routed must comply with local regulations and specifications.



Please carry out construction following relevant construction safety regulations and standards to avoid safety accidents. The person in charge of this product must undergo strict training, master the correct installation method of the system and various safety precautions before proceeding with the equipment.

The installation location should avoid the location of low-lying water accumulation and should be kept at a safe distance from the surrounding fire-explosive facilities and underground pipelines. The installation location should be away from open flames, high temperature, dust and corrosive environment. The protection grade of the selected product enclosure should be compared with the installation environment adapt.

The installation position strength must meet the requirements, all fixing bolts should be tightened, Otherwise there is a risk of falling and dumping. Install the selected cables, terminals and other components to meet the current requirements. Before and after installation, ensure that all wiring related to the charging equipment is tight, well insulated, wired correctly, no wear and crush damage, Otherwise there is a risk of fire and electric shock.

Before powering the device, confirm that the device is well grounded to avoid electric shock. If any part is damaged during installation, it should be repaired and replaced in time to avoid damage.

Operation and maintenance risk notification

 Dangerous	There is dangerous voltage in the equipment when the system runs, and non-professionals should not operate and maintain it.
 Dangerous	Before maintaining the system clean, electrical connection, and ground connection, be sure to cut off power . Otherwise, there is a risk of electric shock and fire.

Equipment operation and maintenance must comply with electrical safety operating procedures, Otherwise there is a risk of fire and electric shock.

The personnel responsible for the operation and maintenance of this product must have the qualifications of high voltage and alternating current, etc., He must undergo strict training, master the correct operation method of the system and various safety precautions, and then carry out various equipment operations otherwise there may be a risk of electric shock.

The energy storage equipment shall not be maintained when the power is not disconnected, otherwise there will be a risk of electric shock.

It is strictly forbidden to wear conductive objects such as watches, bracelets, rings, etc, on the wrist during operation.

There shall be no flammable and combustible materials around the energy storage equipment, and the operation and maintenance personnel shall clean up in time, Otherwise there is a fire risk.

Operation risk notification

Do not use the system in the event of equipment failure. Do not operate without authorization when the equipment is abnormal.

Please strictly follow the operating procedures and instructions on the energy storage equipment, and comply with the industry's safety regulations, Otherwise there will be electric shock and fire risks.

Accidents such as fires, flooding of energy storage facilities, etc, are strictly forbidden to be close to energy storage equipment. Please inform personnel familiar with the equipment and emergency treatment methods for emergency treatment.

Modification record

The Document version A00 (2019.03.04)

The First release

The Document version A01 (2019.05.07)

1.2 Modify Working Mode

2.3.2 Add electrical connection diagram

3.1 Update pictures of APP

3.6.2 Note about Battery Lower Limit SOC

4.2 Add Software upgrade

5.3 Update Trouble Shooting

The Document version A02 (2019.06.03)

2.2.2 Update Figure2-2

2.3.2.4 Update Communication cable connection

The Document version A03 (2019.06.22)

2.3.2 Electrical Connection

Update Figure 2-13

The Document version A04 (2019.08.17)

4.2 Software upgrade

The PCU software name is changed to "PCU5KSL.bin"

The DSP software name is changed to "DSP5KSL.bin"

The Document version A05 (2019.12.04)

4.2 Software upgrade

Added to ensure the inverter is "OFF" before software upgrade

The Document version A06 (2020.05.30)

2.2.1 Update Figure 2-1, Figure 2-2

2.3.2.4 Update Figure 2-23

The Document version A07 (2021.04.28)

3 Sermatec Mate APP

4 System Commissioning

The Document version A08 (2021.09.28)

3 delete Sermatec Mate APP descriptions

4 delete software upgrade descriptions in System Commissioning

The Document version A09 (2022.09.07)

Modify Indicator Description

Modify Technical Parameters

The Document version A10 (2022.12.12)

Modify Technical Parameters

Contents

1 Summary	1
1.1 The description of the model	1
1.2 Compose and Operating Principle	1
2 Installation	7
2.1 Safety regulations	7
2.2 Installation preparation	8
2.3 Installation	10
2.4 Installation check	21
3 Sermatec APP	23
3.1 Software acquisition	23
3.2 Connect to internal Wi-Fi	23
4 System Commissioning	24
4.1 Check before commissioning	24
4.2 Power on and Off	24
5 Product Maintenance	26
5.1 Routine Maintenance	26
5.2 LED Status	27
5.3 Trouble Shooting	28
6 Technical Parameters	38

1 Summary

The 5kW all-in-one hybrid inverter (hereinafter referred to as the Hybrid Inverter) can realize Hybrid Inverter for photovoltaic charging, DC terminal battery charging and discharging, and AC terminal grid-connected applications.

This chapter describes the model, composition and configuration and working principle of the Hybrid Inverter.

1.1 The description of the model

Take 5kW power as an example for model description.

Hybrid Inverter model: SMT-5K-TL-LV

The model description is shown below:

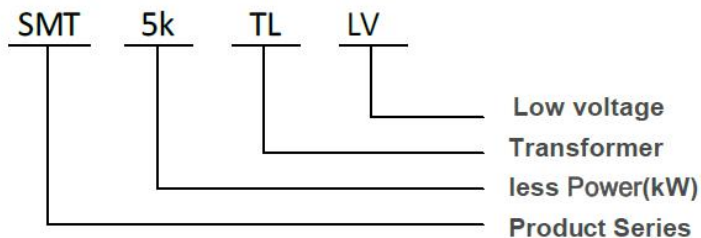

Figure1-1 5kW Hybrid Inverter all-in-one model description

1.2 Compose and Operating Principle

The Hybrid Inverter is composed of a power unit (battery charging and discharging circuit, boost and buck circuit, inverter circuit, auxiliary power source, filter circuit), system control unit, and a system monitoring unit (including a system communication unit) etc.

This product generally applies to solar storage system, the system is mainly composed of PV panels, battery, hybrid inverter, local load, Grid etc. The system can realize the functions of transmitting PV power to Grid, supplying backup load by PV or/and Battery, charging Battery by PV or/and Grid etc. After carefully research, five work modes are well designed to meet most scenarios, ensure the PV power generation effectively, supply the backup load reliably, preserve the service time of the battery as long as possible, etc.

The schematic diagram of the primary circuit of the Hybrid Inverter is as follows: 1. the battery side is considered as DVC-C circuit; 2. The wire N of back up port is connected to grid neutral via internal relay when the unit works in stand-alone mode.

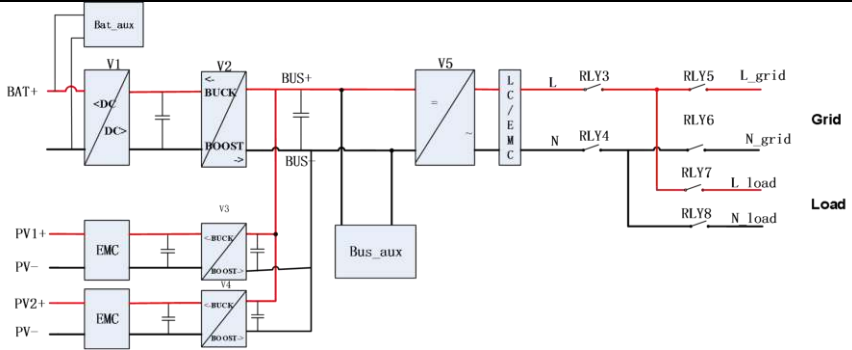

Figure1-2 The Hybrid Inverter principle topology

Work Modes:

Five working modes: General mode, Energy Storage mode, Micro-grid mode, Peak-Bottom mode and AC coupling mode. The Inverter must be configured in APP before powering on: working parameters (Grid standard, DC side battery type, battery protocol, meter protocol), working mode, (working mode, utility power price, period setting) ,and other parameters if necessary. As shown in the figures below:

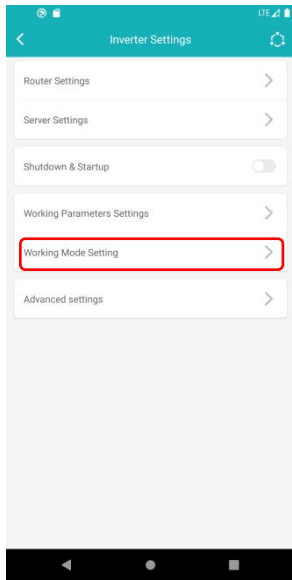

Figure1-3

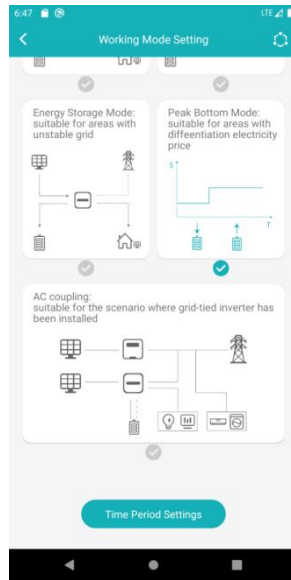
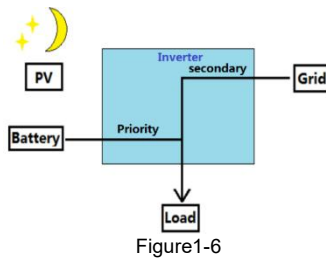
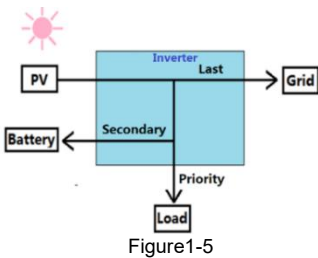

Figure1-4

Mode 1: General mode (Default)

Suitable for Areas with Stable Grid

1. If PV power is sufficient, PV power will supply to the load, then charge the battery, feeding into a grid at last if still surplus power (Anti-back-flow is forbidden). (Figure1-5)
 2. When PV power is insufficient, batteries and the grid supply power to the load together with insufficient PV. (Figure1-6)
 3. Anti-back-flow is default disabled.
- Typical application scenarios:



Mode 2: Energy Storage mode

Suitable for Areas with Unstable Grid

1. PV and grid supply power to load and charge batteries together. (Figure1-7)
 2. When the Grid is normal, the battery SOC is always in full state.
 3. Batteries discharge only when the grid is abnormal.
 4. Anti-backflow is default to enable.
- Typical application scenarios:

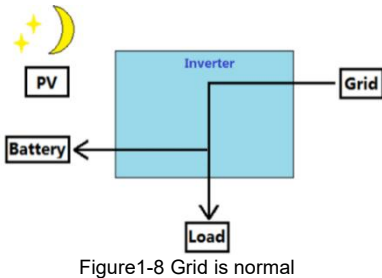
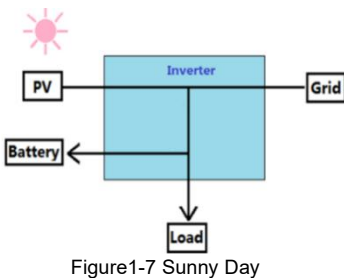

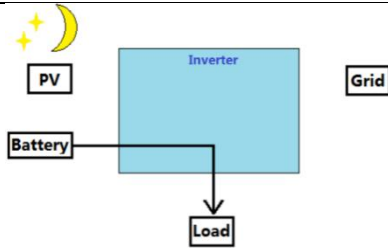

Figure1-9 Grid is abnormal

Mode 3: Micro-grid mode

Suitable for Areas without Grid

1. The Micro-grid power source comes from PV, battery.
2. If PV is sufficient, PV power will supply to the load, then charge the battery. (Figure1-10)
3. When PV is insufficient, Battery supplies power to the load. (Figure1-11)

Typical application scenarios:

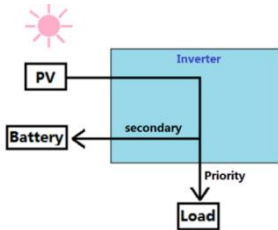

Figure1-10 Sunny day

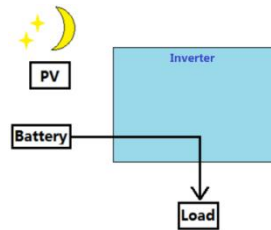

Figure1-11 Night

Mode 4: Peak-Bottom mode

Suitable for Areas with Changing Electricity Price

According to the electricity price of utility, the whole day can be divided into four periods (most of the place): tip, peak, flat and bottom price.

1. During the price of the bottom period, the grid or/and PV charge the batteries and supply to loads together to storage the electric power. Battery never discharge at this stage.
2. During the price of the flat period, when the PV is sufficient, it provides power in the sequence of load, battery and grid.
3. During the price of tip and peak period, the battery and PV provides power to the load, if more energy will sell to Grid to obtain profit. Battery never charges at this stage.

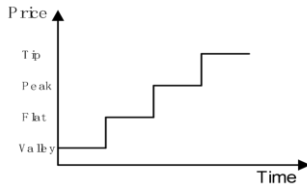

Figure1-12 Grid price

In Bottom Time Period:

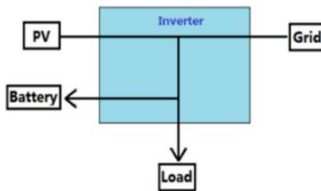

Figure1-13

In Flat Time Period:

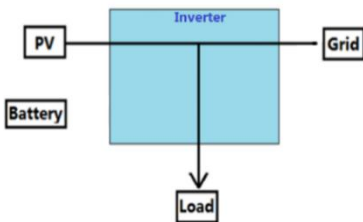

Figure1-14 PV is insufficient

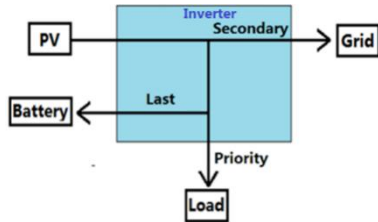

Figure1-15 PV is sufficient

In Tip and Peak Time Period:

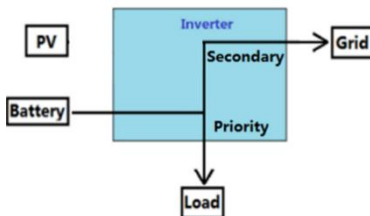

Figure1-16 PV is insufficient

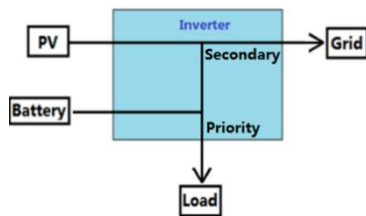

Figure1-17 PV is sufficient

Mode 5: AC Coupling mode

Suitable for the scenario that grid-tied inverter already there

Cooperate with the existing grid-tied inverter to build a storage system to get more profit. The joint point is the Grid side or AC terminal.

1. Inverter communicates with CT (smart meter), CT is used to detect the on-grid power;
2. When PV surplus, battery with low SOC (less than 100%) : Surplus PV will firstly provides to loads(backup loads and AC grid loads),then charge the battery ,lastly sell to grid;
3. When PV surplus, battery with full SOC: PV supply power to the load firstly, and then the rest power of PV will feed into the grid;
4. When PV insufficient: Battery and PV supply power to the load simultaneously; Battery and grid supply power to the load simultaneously when battery with lower limit of SOC or discharge power not enough;
5. Off-grid: Battery supply power to backup load;
6. APP will display: Battery charge/discharge power; Backup load power; AC grid load power, and on-grid power.

Note: CT must be installed under AC-coupling working mode, CT self-checking default enabled, the device will not start if the CT self-checking(meter detection) failed.

Meter/CT here only communicates with hybrid inverter, so if you enable anti-backflow it works for hybrid inverter only, cannot work on grid-tied inverter as Sermatec inverter cannot control the grid-tied inverter.

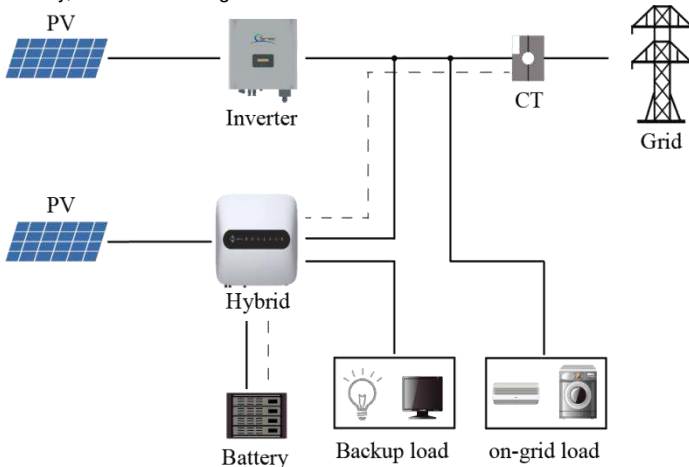

2 Installation

This chapter describes the installation and wiring of the Hybrid Inverter. Please strictly follow the instructions in this chapter to install and wire connection.

2.1 Safety regulations

The Hybrid Inverter has high voltage and large current inside. To ensure personal safety, the following regulations should be noted at all times.

The Hybrid Inverter can only be installed by personnel who have received training in the Hybrid Inverter and have a good knowledge of the Hybrid Inverter. During the installation process, always observe the safety precautions and local safety regulations before the catalog of this manual;

Do not operate or maintain the inside of the system during thunderstorms or wet weather to prevent electric shock;

If operating inside the Hybrid Inverter, ensure the system is not powered on.

If the hybrid inverter is equipped with an anti-theft lock, please be sure safe keeping of the key.

2.2 Installation preparation

2.2.1 Unpacking inspection

Only when the goods arrive at the installation site can the unpacking box be allowed to be inspected. The inspection is completed by the customer's representative and the supplier's representative. Unpack the package, review the checklist.

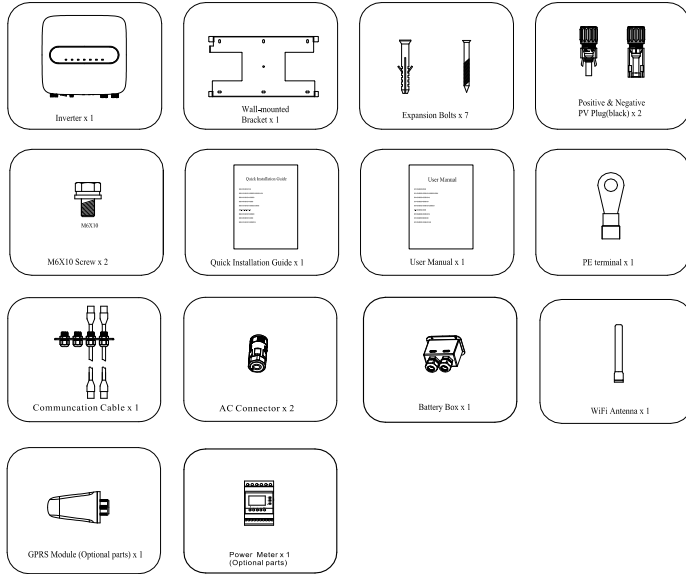

Figure2-1 Packing list

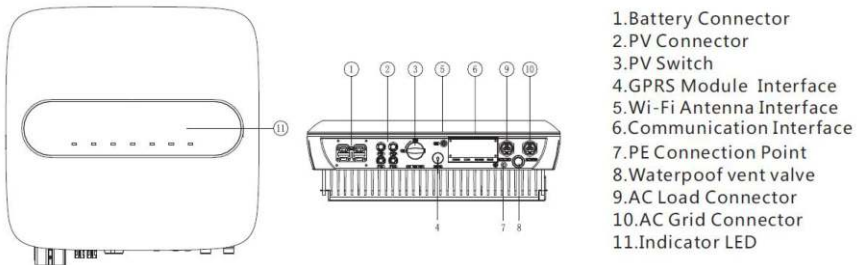

Figure2-2 The Hybrid Inverter Overview

2.2.2 Cable and Air switch preparation

Serial	Cable Name	Recommended model	cross-sectional area (mm ²)	Color of cable	Cable OD (mm)
1	PV side DC positive and negative input	UL1015 12AWG	3.31	Red、Black	4.00±0.15
2	Battery side DC positive and negative input	UL10269 4AWG	16-25	Red、Black	10.00±0.30
3	AC output	UL1015 10AWG	4~6	Red、Black Yellow-Green	4.60±0.20

Note: Be sure all cables withstand voltage, temperature-resistance equal to or better than the recommended model, and complying with relevant regulation of the electrical industry.

Selection of switch

Recommended DC switch		
	PV(option)	Battery(option)
Rated voltage	≥580V DC	≥58V DC
Rated current	16A	160A

Table 2-2

Recommended AC switch		
	AC Load	AC Grid
Rated voltage	≥250V AC	≥250V AC
Rated current	32A	32A

Table 2-3

2.2.3 Installation Kit

1. Electric drill (drilling bit: $\varnothing 8\text{mm}$)
2. Screwdriver (Philips screwdriver: M3、M6; Flathead screwdriver: M3)
3. Wire stripper(4~6mm²)
4. Wire crimper 1 (Model: H4TC0001; Manufacturer: Amphenol)
5. Wire crimper 2(OT terminal, 4~6 mm²)
6. Open-end wrench (Model: H4TW0001; manufacturer: Amphenol)
7. Multimeter

2.2.4 Installation requirements

1. Wall bracket Installation

1) It is necessary to ensure that the installation position is flat and the thickness of the whole wall exceeds 100mm.

- 2) Ensure the installation wall is vertical to the ground. If it is sloping, the tilt angle is only allowed to be less than 15° .
- 3) Ensure the installation wall is solid enough to meet the requirements of load bearing for the hybrid inverter.
- 4) The mounting position is supposed to avoid direct sunlight.

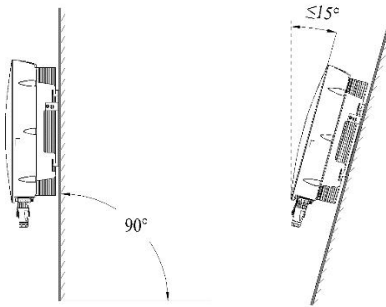

Figure 2-3 Perpendicularity requirement

2. Installation space requirements

Product installation position, leave 300 mm of space for maintenance and heat dissipation left, right and front

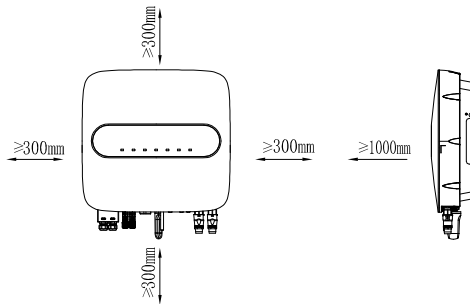

Figure 2-4 Mounting distance

2.3 Installation

2.3.1 Mounting

STEP 1: Mark mounting hole on the wall Drill hole with 8mm diameter of bit. Ensure a depth of 80mm.

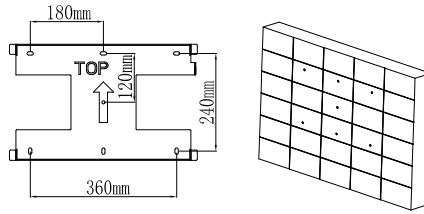

Figure 2-5 Mounting hole

STEP 2: Hammer expansion tube into the wall mount bracket on the wall, keep aligned with the holes.

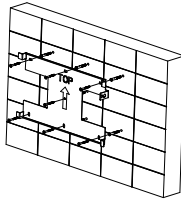

Figure 2-6

STEP 3: Mount the Sematec hybrid inverter on the bracket.

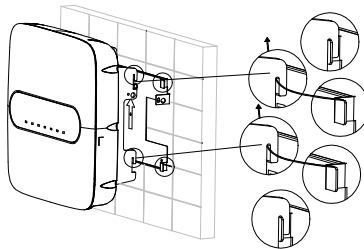

Figure 2-7

STEP 4: Secure the inverters with M6 screw on the right side.

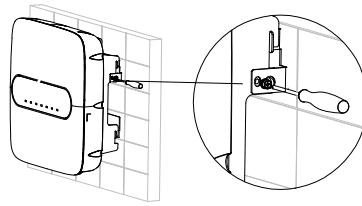

Figure 2-8

STEP 5: Install anti-theft lock if necessary (Optional, equipped by user).

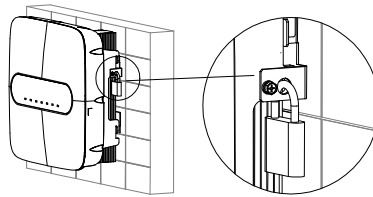

Figure 2-9

2.3.2 Electrical Connection

Hybrid Inverter System Connection Diagram

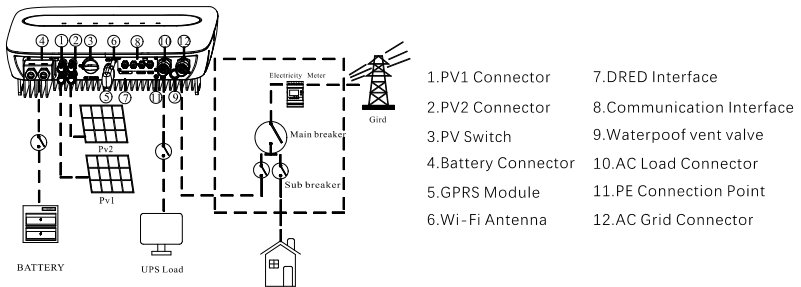

Figure 2-10 Hybrid Inverter System connection Diagram

For AU/EN:

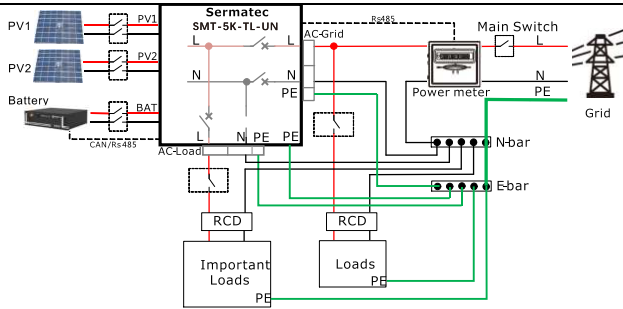

Figure 2-11

For Other Countries:

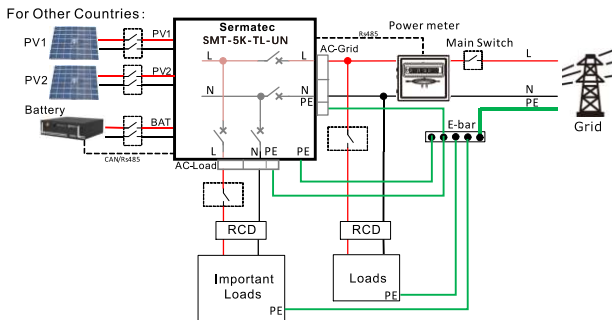

Figure 2-12

Power Meter connection diagram:

Recommended DC Switch		
	PV (option)	Battery (option)
Rated Voltage	≥580VDC	≥58VDC
Rated Current	16A	160A

Recommended AC switch		
	AC Load	AC Grid
Rated voltage	≥250V AC	≥250V AC
Rated current	32A	32A

The Power Meter connection diagram:

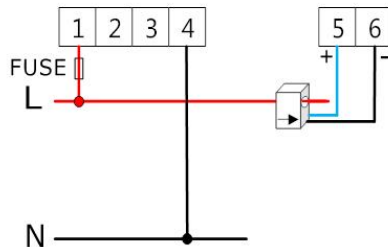

Figure 2-13 (Acrel Single phase Meter)



Dangerous

- 1) Make sure all switches are at the closed(disconnect) position before the electrical connection.
- 2) Only qualified installation person can implement the installation of AC and DC input cable.

2.3.2.1 Connect PV cable



Attention

It is strictly prohibited to connect positive poles (PV1+, PV2+, BAT+) and negative (PV1-, PV2-, BAT+) reversely or incorrectly. Otherwise it would affect normal operation, or even cause damage and other serious consequence.

The length of the external cable to the PV side and battery side is suggested to be less than 30m. PV array should not be connected to the grounding conductor.

The minimum insulation resistance to the ground of PV panels must exceed 34kΩ, there is a risk of shock hazard if the minimum resistance requirement is not met.

STEP 1: Check and verify PV rotary switch is at the OFF position.

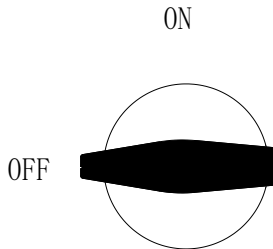

Figure 2-14

STEP 2: Follow the requirement to crimp and connect the H4 connector to a cable which can find from installation kits.

Crimp the H4 connector to the cable as required.

PV Connectionsteps:

PV cable size: 4~6mm²

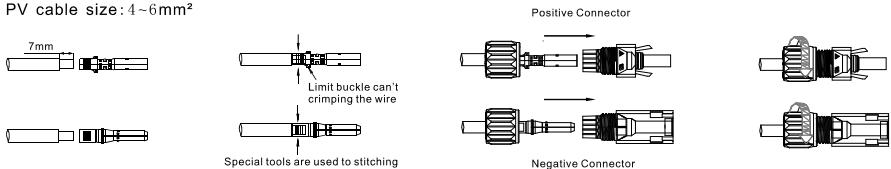

Figure 2-15

STEP 3: Use multimeter to measure PV side voltage and verify correct polarity, ensure the open-circuit voltage is less than 580V.

Hybrid Inverter System connection Diagram

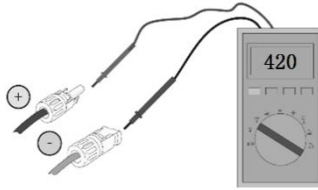

Figure 2-16 PV Polarity check

2.3.2.2 Connect BAT cable



Attention

Make sure that the installation location meets the following conditions:

The area is completely waterproof.

The floor is flat and level.

Batteries should not be connected to the grounding conductor.

The ambient temperature is within the range from 0° C to 50° C.

The temperature and humidity are maintained at a constant level.

There is minimal dust and dirt in the area.

Batteries need to comply with local regulations.

Suggestion: If the battery is to be installed indoor, for details please refer to the battery Manufacture`s user manual.

Suggestion: Batteries must be installed at a distance from each other; for details please refer to the battery manufacture`s user manual.

As for the number of cells used, it will be decided by customer`s choice; The choice must comply with the following requirement: the voltage is 40-58V.

STEP 1: Connect positive and negative terminals to the corresponding interfaces

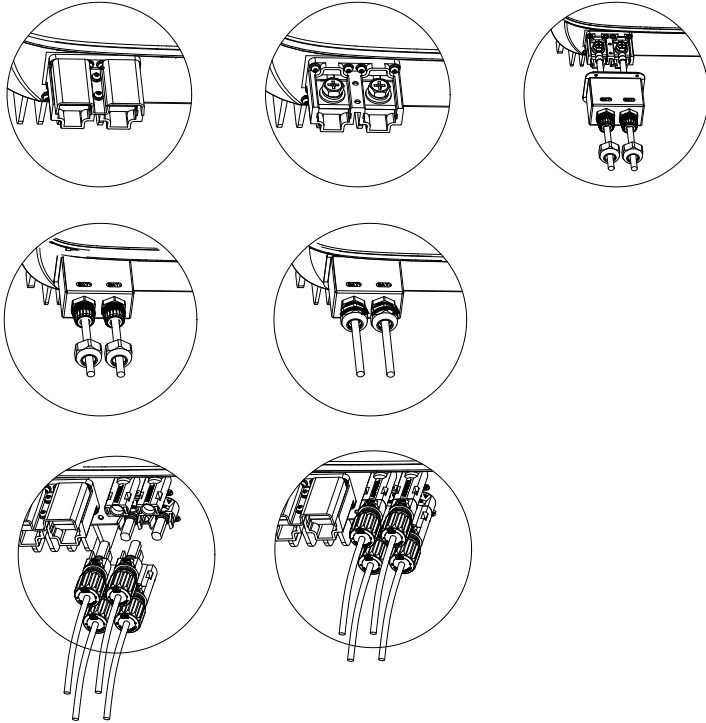

Figure 2-17 Battery terminals connection

STEP 2: Use multimeter to measure Battery side voltage and verify correct polarity, ensure open-circuit voltage is less than 58V.

2.3.2.3 AC output cable connection



Attention

PE cable should be connected properly and reliably, otherwise it would affect normal operation, even cause product damage and serious consequences.

Both PE ground terminals in the connector and ground point on the enclosure can be earthed simultaneously.

Don't reversely connect PV input cable and battery power cable to interfaces! Otherwise, it will affect normal operation.

Don't reversely connect the AC backup load connector and AC Grid connector, AC backup load cable, and AC Grid cable! Otherwise, it will affect normal operation.

STEP 1: The connector and cable are required to be reliably connected as shown below. Order of connection is L (Red), N (Black), PE

Cable sectional are 6 mm², stripping length 6mm

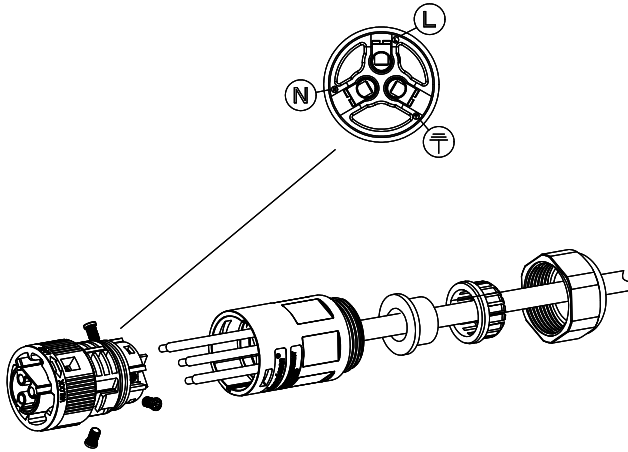

Figure 2-19

STEP 2: Measure grid voltage by multimeter, ensure grid voltage is less than the high limit of voltage required by all national grid standards.

STEP 3: Connect connector to AC Load interface and grid interface, rotate and lock them.

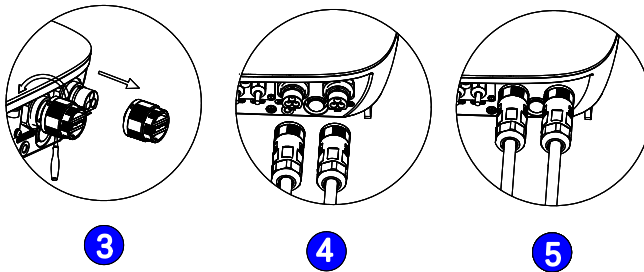

Figure 2-20

Note: Do not connect reverse the backup load side connector and the grid side connector.

STEP 4: PE Installation

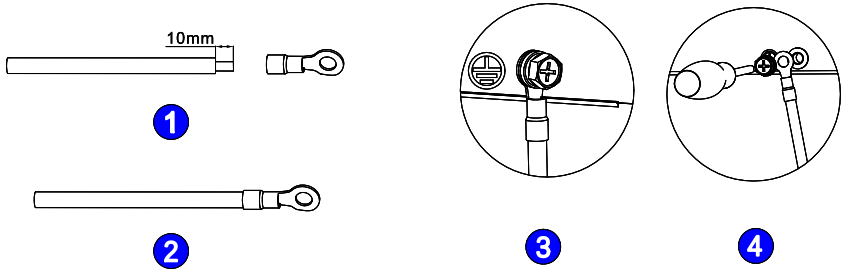

Figure 2-21

2.3.2.4 Communication cable connection

STEP 1: Remove the waterproof cover plate that comes with the Hybrid Inverter

STEP 2: Plug the wire connector of the waterproof cover plate in the accessory into the corresponding interface of the Hybrid Inverter.

STEP 3: Fix firmly by screw.

STEP 4: Screw up the water-proof cylinder, connect the cable from the “RS485” interface to the interface of the Power Meter, connect the cable from the “To battery” interface to the BMS interface in the battery (default length of cable is 3m)

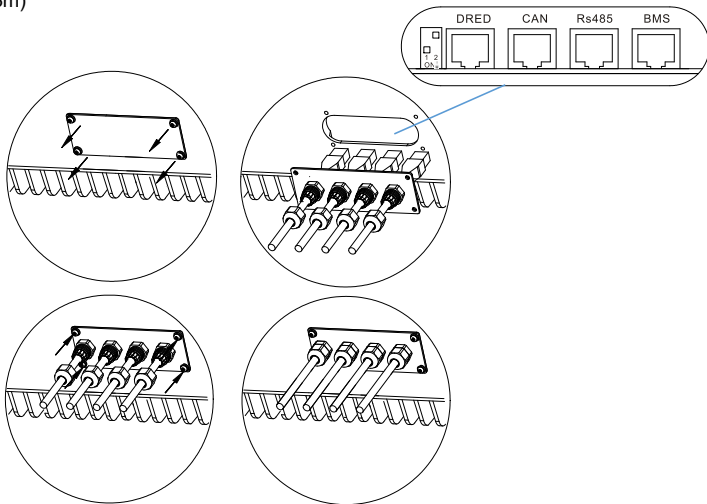

Figure 2-22 Communication cable connection diagram

DRED , Power Meter and BMS Connection:

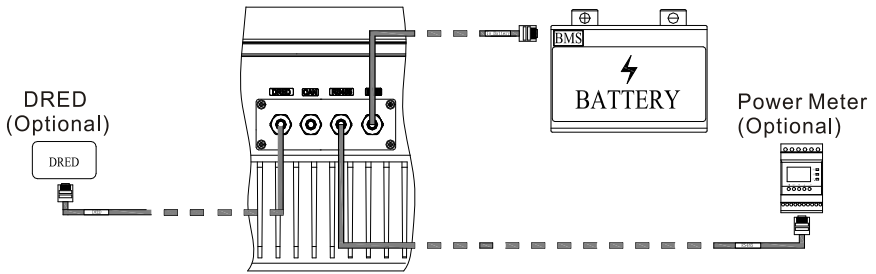
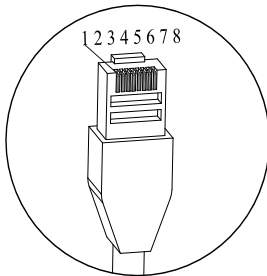

Figure 2-23

The RJ45 socket pin assignments for DRED, Power Meter and BMS as follows:





DRED		
PIN	Signal Name	Cable Color
1	DRM 1/5	Orange-white
2	DRM 2/6	Orange
3	DRM 3/7	Green-white
4	DRM 4/8	Blue
5	RefGen	Blue-white
6	Com/DRM0	Green
7	N/A	Brown-white
8	N/A	Brown

RS485		
PIN	Signal Name	Cable Color
1	NC	Orange-white
2	NC	Orange
3	485B_B	Green-white
4	COM	Blue
5	COM	Blue-white
6	485B_A	Green
7	485B_B	Brown-white
8	485B_A	Brown

BMS		
PIN	Signal Name	Cable Color
1	485A_B	Orange-white
2	485A_A	Orange
3	COM	Green-white
4	CAN_H	Blue
5	CAN_L	Blue-white
6	COM	Green
7	485A_A	Brown-white
8	485A_B	Brown

Figure 2-24

If you need to use DRED function, please put the left dip switch to the upper position.

The State of dip switch	Function
	DRED Enable
	DRED Disable

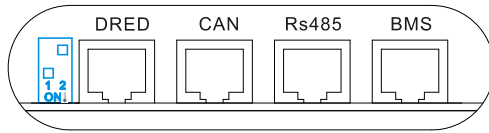

Figure 2-25

The inverter shall detect and initiate a response to all supported demand response commands, demand response modes are described as follows:

Table 2-4

Mode	Requirement
DRM 0	Operate the disconnection device
DRM 1	Do not consume power
DRM 2	Do not consume more than 50% of rated power
DRM 3	Do not consume at more than 75% of rated power AND Source reactive power if capable
DRM 4	Increase power consumption(subject to constraints from other active DRMs)
DRM 5	Do not generate power
DRM 6	Do not generate at more than 50% of rated power
DRM 7	Do not generate at more than 75% of rated power AND Sink reactive power if capable.
DRM 8	Increase power generation(subject to constraints from other active DRMs)

2.3.2.5 GPRS Module (Optional) and Wi- Fi Antenna Connection

If the user selects the GPRS module, remove the dust cover plate of the GPRS module interface and install the GPRS module.

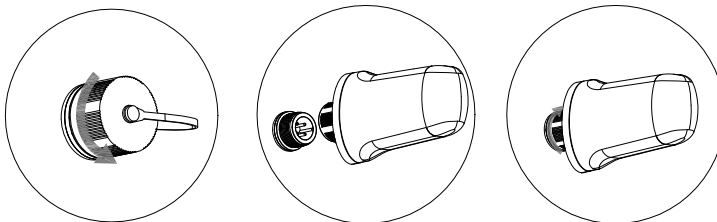

Figure 2-26

The GPRS socket pin assignments as follows:

PIN	Signal Name
1	VCC
2	GND
3	485A
4	485B

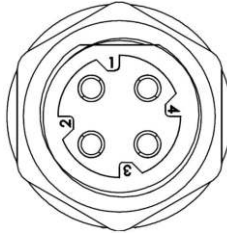

Figure 2-27 GPRS socket Pin

If WiFi used, please install the antenna to the antenna socket.

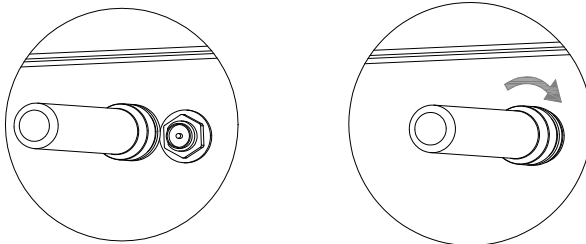

Figure 2-28 WiFi antenna diagram

2.4 Installation check

After the Hybrid Inverter is installed, be sure to check the installation according to the following table!

Table 2-5 Installation checking list

Check item	Series	Check content
Installation	1	Check whether the Hybrid Inverter installation is vertical and stable.
	2	Check that all bolts are tight (especially pay attention to the electrical connection), whether the flat washers and spring washers are complete, and whether they are installed in reverse.
	3	Check whether the reserved distance below the Hybrid Inverter meets the requirements.
	4	Check whether the accessories are complete and the cable is intact and not damaged.
Electrical	1	Check PV cable polarity, ensure they are connected properly.

Check item	Serie I	Check content
connection	2	Ensure PV rotating switch is at OFF position
	3	Check load connector , grid connector whether they are connected properly.
	4	Check if the ground point on the enclosure is earthed reliably.
	5	Check the AC and DC connectors whether are reliably connected.
	6	Check that the model specifications of the incoming and outgoing cable are correct.
	7	Check that all cable connections are secure and reliable
	8	Check whether or not the color of AC cables is standardized, with complete security identity.
	9	Check that the cables are neat and that the cable ties are in compliance with the process specifications.

3 Sermatec APP

Sermatec App is used to check and control inverter parameters. There are two modes: Local Connection Mode and Web Cloud Mode.

Local Connection Mode: Use the phone to connect to device by WiFi locally, you can check and set device parameters.

Web Cloud Mode: Use Internet to check and control device remotely. After log-in APP, you can use Web Cloud related functions: Check device parameters, issue orders online.

3.1 Software acquisition

- ① Andriod User please visit Google Play, search 'Sermatec' to download.
- ② iOS User please visit App Store, and search 'Sermatec' to download and install.
- ③ Andoriod User please download in Sermatec Official Site:

<https://www.sermatec-ess.com/download-center/>

3.2 Connect to device Wi-Fi

Please flow the steps below to connect to device Wi-Fi for the first time:

- ① Supply the Power to the inverter (Grid, PV or Battery).
- ② Find Wi-Fi name from the label on the inverter and connect to Wi-Fi by initial password "gsstes123456".
(Figure 3-1) .
- ③ Open Sermatec APP, select "Local Connection Mode", check and set device parameters. Refer to the <<Sermatec APP User Manual >>to get the detail information.

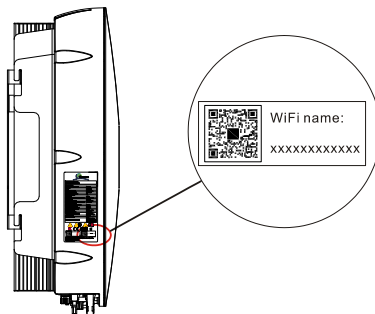

Figure 3-1 Wifi name and password

4 System Commissioning

This Chapter is the instructions for commissioning after installation.

During the process of commissioning, complying with the safety regulation is necessary.

4.1 Check before commissioning



Dangerous

Please contact operation personnel to implement commissioning.

Please take off metal items like a ring, bracelet, watch, etc, which would cause a short circuit.

During the process, pay attention to high voltage danger, avoid personal injury and property loss.

Ensure well-grounded and installation check before commissioning.

Operation personnel is required to check the items in Table 4-1 strictly showed below.

Table 4-1 Checking List

Checking Sequence	Checking Content	Checking Standard	Remark
1	Check to ensure the condition of DC air switch	Switch Off	PV, BAT
2	Check to ensure the condition of PV rotatory switch	Switch Off	PV
3	Use a multimeter to measure PV switch voltage, ensure the voltage is less than 580V		
4	Use a multimeter to measure BAT input switch voltage, ensure the voltage is less than 58V		
5	Check to ensure the condition of AC air switch	Switch Off	Grid , Load
7	Ensure battery powering on is normal	Normal	RS485 (optional)
8	Check to ensure battery communication is normal	Normal	Battery BMS
9	Check to ensure grid and loads work normally	Normal	Grid, Load

4.2 Power on and Off

Power ON steps:

STEP 1: Close PV rotatory switch, PV input switch (option), BAT input switch, AC side switch, Load side switch.

STEP 2: Run Sermatec App(local connection mode), connect to the inverter, and check if there is some abnormal warning.

STEP 3: If there is no warning, setting **Grid standard** (must), **Battery type** (must), then click "Proceed."

STEP 4: Setting **Working mode** (Must) in your application.

STEP 5: Setting other parameters (Optional) such as: Price setting, Period setting and etc.

STEP 6: Click the "startup" button to power on the inverter.

STEP 7: Check and observe running data and status on the parameters page for several minutes.

STEP 8: Click the "Warning" button to check the system fault info if any fault occurred.

Power OFF steps:

STEP 1: Click the "Shutdown" button in the "Setting" menu to power off the inverter.

STEP 2: Open the switches if needed.

5 Product Maintenance

This chapter mainly introduces routine maintenance, troubleshooting.



Dangerous

- ①. You will be obliged to implement product maintenance complying with the safety regulations.
- ②. The personnel to implement the internal operation of inverters must be trained and qualified with sufficient knowledge of the electrical systems.
- ③. It is required to implement powering down before the system clean, confirming the reliability of electrical connection, the ground connection, etc.

STEPS to power off

- a. Run APP, execute the shutdown command, and please refer to Chapter 4.2
- b. Sequentially disconnects
 - ①. PV side switch,
 - ②. Battery side switch,
 - ③. PV rotatory switch on the inverter,
 - ④. AC grid side switch
 - ⑤. AC load side switch.

5.1 Routine Maintenance



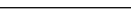

















Table5-1

Checking Content	Checking Method	Maintenance Period
System Clean	Periodic inspection for cooling fan, clean out dust	Once in six months to one year
System running status	1. Observe the physical appearance of inverter to determine whether it is damaged or deformed. 2. If there is any noise from the inverter during the operation. 3. During the operation, check and ensure all parameters are set properly.	Once in six months.
Electrical Connection	1. Check if the cable connections loosen. 2. Check if cables are damaged, especially for bus cables.	Half a year after first

	<p>3. Check if there are signs of cuts on the coat contacted with the metal's surface.</p> <p>4. Check if the cylinders on the unused DC input terminal and unused GPRS interface are tightened.</p>	<p>commissioning.</p> <p>Once half a year to one year afterward.</p>
Grounding reliability	Check if the grounding cable is grounded firmly.	

5.2 LED Status

Table5-2

Display item	Status	Corresponding state description
SYSTEM		On: System is active and on-grid
		Blink: System is active and off-grid
		Off: System is standby
BACK-UP		On: AC-Load is active and normal
		Blink: AC-Load is active and overload
		Off: AC-Load is off
SOLAR		On: All PV is normal
		Blink: One PV is abnormal
		Off: All PV is abnormal
BATTERY		On: Battery is normal
		Blink: Voltage of battery is low
		Off: Battery is abnormal
GRID		On: Consuming electricity
		Blink: Generating electricity
		Off: Grid is abnormal
WIFI		On: Inverter is in Local Connection Mode
		Fast Blink: Inverter is trying to connect to Router Wifi
		Slow Blink: Inverter has successfully connected to Router Wifi
		Off: Wi-Fi is not active
FAULT		On: Fault has occurred
		Off: No Fault

5.3 Trouble Shooting

Table 5-3

Error message	Fault cause	Solutions
Grid Phase Lock Failure	Abnormal frequency or voltage of the grid	<ol style="list-style-type: none"> 1. Shut down and turn on when the power grid is normal. 2. If step 1 does not help, please contact Sermatec Service team.
AC Output Short Circuit Error	AC backup or AC Grid port have short circuit issue	<ol style="list-style-type: none"> 1. Shut down inverter and check the circuit, restart after correction. 2. If step 1 does not help, please contact Sermatec Service team.
Output Current Leakage Error	Abnormal electrical connection	<ol style="list-style-type: none"> 1. Shut down inverter and check the AC output circuit, ensure PE is grounded well, restart after correction. 2. If step 1 does not help, please contact Sermatec Service team.
	The leakage current of the load exceeds the standard.	Make sure the leakage current of load meets the standard(less than 230mA).
AC Output Overload Warning	The output power exceeds the upper limit of output power.	<ol style="list-style-type: none"> 1. Please check backup load power to see if it is overloaded; <ol style="list-style-type: none"> A. For 10K inverter, none-inductive load cannot be more than 10kW (each phase is not more than 3.3kW). The inductive load cannot be more than 3.3kW (each phase is not more than 1.1kW). B. For 5K inverter, none-inductive load cannot be more than 5kW, the inductive load cannot be more than 1.7kW.
Inverter Soft Start Up Failure	Inverter AC Voltage	1. Occasional failures can

	lower than local grid code voltage range	<p>automatically recover.</p> <p>2. The inverter cannot automatically recover, shut down, and turn on when the power grid is normal. If it still cannot self-recover, please contact the Sermatec service team.</p>
Grid Frequency Low Warning	The frequency of the grid is lower than the lower limit	<p>1. Check grid frequency, and restart the inverter after the grid frequency recover to normal range.</p> <p>2. If step 1 does not help, please contact Sermatec Service team.</p>
Grid Frequency High Warning	The frequency of the grid is higher than the upper limit	<p>1. Check grid frequency, and restart the inverter after the grid frequency recover to normal range.</p> <p>2. If step 1 does not help, please contact Sermatec Service team.</p>
Grid Voltage Low Warning	The voltage of the grid is lower than the lower limit	<p>1. Check grid voltage, and restart the inverter after the grid voltage recover to normal range.</p> <p>2. If step 1 does not help, please contact Sermatec Service team.</p>
Grid Voltage High Warning	The voltage of the grid is higher than the upper limit	<p>1. Check grid voltage, and restart the inverter after the grid voltage recover to normal range.</p> <p>2. If step 1 does not help, please contact Sermatec Service team.</p>
PV2 Undervoltage Warning	PV2 no voltage	Make sure the PV2 connection is normal, and the switch is closed.
	The voltage of PV2 is lower than the lower limit	<p>1. Check PV2 configuration, increase PV2 open-circuit voltage.</p> <p>2. If step 1 does not help, please contact Sermatec Service team.</p>
PV2 Overvoltage Warning	The voltage of PV2 is higher than the upper limit	<p>1. Check PV2 configuration, reduce PV open-circuit voltage.</p> <p>2. If step 1 does not help, please contact Sermatec Service team.</p>
	PV1 no voltage	Make sure the PV1 connection is

PV1 Undervoltage Warning		normal and the switch is closed.
	The voltage of PV1 is lower than the lower limit	<ol style="list-style-type: none"> 1. Check PV1 configuration, increase PV2 open-circuit voltage. 2. If step 1 does not help, please contact Sermatec Service team.
PV1 Overvoltage Warning	The voltage of PV2 is higher than the upper limit	<ol style="list-style-type: none"> 1. Check PV1 configuration, reduce PV1 open-circuit voltage. 2. If step 1 does not help, please contact Sermatec Service team.
Reverse PV2 Warning	PV2 positive and negative poles reversed connected	<ol style="list-style-type: none"> 1. Check cable connection, resume to work when going back to normal. 2. If step 1 does not help, please contact Sermatec Service team.
Reverse PV1 Warning	PV1 positive and negative poles reversed connected	<ol style="list-style-type: none"> 1. Check cable connection, resume to work when going back to normal. <p>If step 1 does not help, please contact Sermatec Service team.</p>
Bus Software Start Up Failure	Inverter Damage	<ol style="list-style-type: none"> 1. Occasional failures can automatically recover. 2. The inverter cannot automatically recover, shut down, and turn on when the power grid is normal. If it still cannot self-recover, please contact the Sermatec service team.
Bus Hardware Start Up Failure	Inverter Damage	<ol style="list-style-type: none"> 1. Occasional failures can automatically recover. 2. The inverter cannot automatically recover, shut down, and turn on when the power grid is normal. If it still cannot self-recover, please contact the Sermatec service team.

<p>DC Bus Capacitor Undervoltage Warning</p>	<p>Inverter Damage</p>	<ol style="list-style-type: none"> 1. Occasional failures can automatically recover. 2. The inverter cannot automatically recover, shut down, and turn on when the power grid is normal. If it still cannot self-recover, please contact the Sermatec service team.
<p>DC Bus Capacitor Overvoltage Warning</p>	<p>Inverter Damage</p>	<ol style="list-style-type: none"> 1. Occasional failures can automatically recover. 2. The inverter cannot automatically recover, shut down, and turn on when the power grid is normal. If it still cannot self-recover, please contact the Sermatec service team.
<p>DC Bus Voltage Imbalance Warning</p>	<p>The load is a half-wave load.</p>	<ol style="list-style-type: none"> 1. Occasional failures can automatically recover. 2. The inverter cannot automatically recover, shut down, and turn on when the power grid is normal. If it still cannot self-recover, please contact the Sermatec service team.
	<p>Inverter Damage</p>	
<p>Battery SOC Lower Than The Lower Limit Error</p>	<p>Low Battery SOC</p>	<ol style="list-style-type: none"> 1.Short time failure is normal, waiting for PV or grid to charge; 2. It is recommended to turn off the inverter when there is no PV or power grid for a long time. Turn on when PV or grid is normal. 3. increase the discharge SOC lower limit setting in Sermatec Mate APP. 4. If above steps cannot help please contact the Sermatec service team.
<p>Battery Charge/Discharge Overcurrent Warning</p>	<p>Battery current is lower than the requirement.</p>	<ol style="list-style-type: none"> 1.Occasional failures can automatically recover. 2.Reduce the load. 3.Change the battery. 4.Reduce the charge or discharge current in Sermatec Mate APP. 5.If above steps cannot help please contact the Sermatec service team.
	<p>BMS send wrong fault</p>	<ol style="list-style-type: none"> 1.Shutdown Battery system and power on again. 2.Change the battery.

		3. Get help from battery supplier.
AC Grid and AC Back-up Load Cables Connected Inversely Error	Connector Installation Errors on AC Grid Side and Back-up Load Side	<ol style="list-style-type: none"> 1. Connect the cables to the correct terminal. Otherwise, there will be severe consequences. (For 5K, the error will persist until you correct the cables; for 10K it will pop up this error before powering on and will not allow you to power on inverter before you correct the cables, but if the 10K is running without grid and now connecting to grid the 10K will be damaged.) 2. If step 1 does not help, please contact the Sermatec service team.
Battery Overvoltage Warning	Battery voltage is higher than the upper limit	<ol style="list-style-type: none"> 1. Check battery voltage, reduce battery voltage or change battery; 2. If step 1 does not help, please contact the Sermatec service team.
Battery Undervoltage Warning (EOD)	Battery voltage is lower than the lower limit	<ol style="list-style-type: none"> 1. Check battery voltage, increase battery voltage or change battery. 2. If step 1 does not help, please contact the Sermatec service team.
	Battery discharged too much	<ol style="list-style-type: none"> 1. Change work mode to “energy storage” mode to charge the battery SOC to normal range. 2. If step 1 does not help, please contact the Sermatec service team.
PV+ Insulation Impedance Fault	Insulation impedance is less than the limit value	<ol style="list-style-type: none"> 1. Make sure the insulation impedance of the PV module is greater than 34kΩ. 2. If step 1 is done but error still, please contact the Sermatec service team.

<p>PV- Insulation Impedance Fault</p>	<p>Insulation impedance is less than the limit value</p>	<p>1. Make sure the insulation impedance of the PV module is greater than 34kΩ. If step 1 is done but error still, please contact the Sermatec service team.</p>
<p>PV Bus Software Start Up Failure</p>	<p>Inverter Damage</p>	<p>1. Occasional failures can automatically recover. 2. The inverter cannot automatically recover, shut down, and turn on. If it still cannot self-recover, please contact the Sermatec service team.</p>
	<p>PV Power is not enough</p>	<p>Increase PV power to effective value.</p>
<p>PV Bus Hardware Start Up Failure</p>	<p>Inverter Damage</p>	<p>1. Occasional failures can automatically recover. 2. The inverter cannot automatically recover, shut down, and turn on. If it still cannot self-recover, please contact the Sermatec service team.</p>
<p>Relay Check Failure</p>	<p>Internal relay cannot close or open normally</p>	<p>1. Occasional failures can automatically recover. 2. The inverter cannot automatically recover, shut down, and turn on when the power grid is normal. If it still cannot self-recover, please contact the Sermatec service team.</p>
<p>IGBTA/B/C Temperature Sensor Fault</p>	<p>The actual ambient temperature is too low</p>	<p>No operation is required. When the temperature rises, it will recover by itself.</p>
	<p>Temperature sensor failure</p>	<p>1. Occasional failures can automatically recover. 2. The inverter cannot automatically recover, shut down, and turn on. If it still cannot self-recover, please contact the Sermatec service team.</p>
<p>IGBTA/B/C Temperature Too High Fault</p>	<p>There are something around affecting heat dissipation.</p>	<p>Check if there are anything around that affects heat dissipation, if yes, remove the obstacle.</p>

	There are heat sources around, causing the ambient temperature to be too high.	Keep away from heat sources and reduce the ambient temperature. If the inverter cannot automatically recover after the temperature goes down, shut down, and turn on, if it still cannot self-recover, please contact the Sermatec service team.
	Temperature sensor failure	<ol style="list-style-type: none"> 1. Occasional failures can automatically recover. 2. The inverter cannot automatically recover, shut down, and turn on. If it still cannot self-recover, please contact the Sermatec service team.
APP Cannot Read The Information about Battery	Setting Page Battery Protocol selection error	Choose the right battery protocol in APP
	Communication fault between battery and Inverter	<ol style="list-style-type: none"> 1. Check the battery brand&series is on our approved battery list. 2. Check if you chose the correct battery protocol on the Sermatec Mate App. 3. Check battery voltage by using a multimeter, ensure it is in correct range. 4. BMS cable must be correctly plugged and the wires should be ok, can measure by multimeter. 5. If everything above is normal but still issue, please contact the Sermatec service team.
The Mobile Phone Cannot Connect to Inverter WiFi	The connection between the mobile phone and Wi-Fi failed.	<ol style="list-style-type: none"> 1. Check the WIFI password is correct. 2. shut down and restart inverter.
	The WIFI signal is too weak.	Check the if WIFI antenna is installed correctly.
	The mobile phone is too far from the inverter	<ol style="list-style-type: none"> 1. Move close to the inverter to connect to the inverter WiFi. 2. If step 1 does not help, please contact the Sermatec service team.
Grid Phase Sequence Error	The grid phase sequence is wrong	<ol style="list-style-type: none"> 1. Check and correct the grid phase sequence. 2. If everything above is normal but

		still issue, please contact the Sermatec service team.
Battery Side Bus Software Start Up Failure	Problem in inverter hardware	<ol style="list-style-type: none"> 1. Occasional failures can automatically recover. 2. The inverter cannot automatically recover, shut down, and turn on. If it still cannot self-recover, please contact the Sermatec service team.
Battery Side Bus Hardware Start Up Failure	Problem in inverter hardware	<ol style="list-style-type: none"> 1. Occasional failures can automatically recover. 2. The inverter cannot automatically recover, shut down, and turn on. If it still cannot self-recover, please contact the Sermatec service team.
Bus Level 1 Undervoltage Warning	Inverter Damage	<ol style="list-style-type: none"> 1. Occasional failures can automatically recover. 2. The inverter cannot automatically recover, shut down, and turn on. If it still cannot self-recover, please contact the Sermatec service team.
Bus Level 1 Overvoltage Warning	PV overvoltage	Decrease number of PV modules, or decrease PV open-circuit voltage
	Oscillated	<ol style="list-style-type: none"> 1. Occasional failures can automatically recover. 2. The inverter cannot automatically recover, shut down, and turn on. If it still cannot self-recover, please contact the Sermatec service team.
	Inverter hardware error	<ol style="list-style-type: none"> 1. Occasional failures can automatically recover. 2. The inverter cannot automatically recover, shut down, and turn on. If it still cannot self-recover, please contact the Sermatec service team.
PV Power Supply Weak Warning	Off-grid error, PV power is not enough for load	Increase PV power.
Meter Warning	Meter is not connected effectively	<ol style="list-style-type: none"> 1. Check if you installed the correct model of meter (Acrel or Easton). 2. Check the wiring of the meter. 3. Enable "Meter Detection Function" to check if the meter is connected correctly;

		4.If above steps cannot solve, please contact the Sermatec service team.
Parallel Address Overlimit Warning	Maximum 4 inverters(10K) in parallel	Make sure that the number of 10K inverters connected in parallel are less than 4.
Parallel Cable Fault	Communication cable between 10K is not connected effectively	1.Check if the connection is effective. 2.If the connection is correct, but the error still exists, please contact the Sermatec service team.
Level 2 Bus Software Start Up Failure	Inverter hardware error	1. Occasional failures can automatically recover. 2. The inverter cannot automatically recover, shut down, and turn on. If it still cannot self-recover, please contact the Sermatec service team.
Meter Communication Failure	Meter cannot communicate with inverter	1.Check if you installed the correct brand of the meter,only Acrel and Eastron sepcial series are supported. 2.Check if the communication cable is connected effectively. 3. Use a multimeter to check if the socket pins in the communication cable are effective. 4. If everything above is correct, please contact the service.
Charging/discharging issue	Do not charge or discharge according to normal logic	1.Check Working Mode, check PV power, load power. If everything is normal,; 2. Check if there is any alarm that charge/discharge voltage/current already reach the limit; 3. Check if the SOC already reach the limit; 4. If all above is normal but still problem, please contact the Sermatec service team.
Inverter cannot power on	PV, battery and grid voltage should be in normal working voltage,one of the three could power on inverter if it is above the minimum voltage.	1. Ensure the PV, battery,grid voltage is in normal voltage range according to specifications, ensure PV switch is on,PV polarity is correct if only with PV connected. 2. If all above is normal but still problem, please contact the Sermatec service team.

	Inverter Damage	<ol style="list-style-type: none"> 1. Occasional failures can automatically recover. 2. The inverter cannot automatically recover, shut down, and turn on. If it still cannot self-recover, please contact the Sermatec service team.
SOC value abnormal	Battery SOC changes a lot suddenly (especially for lead acid battery of 5K inverter)	<ol style="list-style-type: none"> 1. Please change work mode to 'energy storage' mode, to charge the battery to full SOC and then check again. 2. If everything above is normal but still issue, please contact the Sermatec service team.
BMS Communication failure	Battery has no data displayed in Sermatec Mate APP.	<ol style="list-style-type: none"> 1. Check the battery type is on our approved battery list. 2. Check if you chose the correct battery protocol on the Sermatec Mate App. 3. Check battery output voltage by using a multimeter, ensure it is in correct range. 4. BMS cable must be correctly plugged and the wires should be ok, can measure by multimeter. 5. If everything above is normal, please contact the Sermatec service team.
Anti-backflow issue	Do not feed electricity to the grid when anti-backflow is Prohibited.	<ol style="list-style-type: none"> 1. Check Working Mode, check PV power, check load power, check if the meter is installed effectively, check warnings for meter. 2. If everything above is normal, please contact the service.
	Feed electricity to the grid when anti-backflow is Enabled.	<ol style="list-style-type: none"> 1. Check if the meter is installed effectively, check warnings for meter. 2. If everything above is normal, please contact the service.
Inverter could power on but no WIFI hotspot	SolarWIFIXXXXXX cannot be found in cellphone	<ol style="list-style-type: none"> 1. Power off the inverter, wait for 10 minutes then power on again to try; 2. If step 1 does not help, please dip the dip switch to reset the inverter, method please consult Sermatec service team;

		3. If step 2 does not help, please contact service team for more solutions.
--	--	---

6 Technical Parameters

Table6-1

Technical parameters	Parameters
PV Input (DC)	
Maximum PV array power(w)	6000
Vmax PV (V)	580
Rated voltage (V)	360
Maximum input current(A)	13/13
Isc PV(A)	14/14
MPPT voltage range	125-550
Number of MPPT trackers	2
Battery input and output	
Battery voltage range (V)	40-58
Rated battery voltage (V)	48
Rated charging/ discharging power(W)	4200/5000
Maximum charging/discharging current(A)	70/100
BMS communication interface	CAN/RS485
Reverse polarity protection	YES
Grid Input/Output parameters	
Grid rated apparent power (VA)	5000
Grid rated voltage (V)	220/230Va.c.
Grid connection	1/N/PE
Grid rated frequency (Hz)	50/60
Grid rated current (A)	21.7
Grid maximum current (A)	22.8
Overcurrent protection(A)	26
Short circuit current(A)	129Apeak, 8.5Arms
Power factor range	0.8 ahead~0.8 behind
Total harmonic distortion (THD, rated power)	<3%
Load Output (With Battery)	

Rated power (VA)	4600
Rated voltage (V)	220/230Va.c.
Electrical connection	1/N/PE
Rated frequency (Hz)	50/60
Maximum current	20.9
Rated current (A)	20
Overcurrent protection(A)	60
Short circuit current(A)	98Apeak, 45Arms
Peak power (W) duration @ Ta=25° C	Support power mode、Overpower 5 kw (30min)、6kw(5min)
UPS switch time (ms)	<20
Total harmonic distortion THD (Linear load)	<3%
Efficiency	
MPPT Efficiency (%)	99.9
Europe Efficiency (%)	97
Max Efficiency (%)	97.8
Battery charge/discharge efficiency (%)	97.6/96
Power consumption	
Standby Self consumption (W)	<25
Standard	
Safety	IEC62109-1-2 / IEC62040
EMC	EN61000-6-1/EN61000-6-2/EN61000-6-3/EN61000-6-4/IEC 62920
Certification	EN50549-1:2019 / AS/NZS 4777.2 / DIN VDE0124-100:2020
Environment limit	
Ingress protection (IP) rating	IP 65
Protective class	class I
Operating temperature range	-25°C...+60°C (>+45°C,derating)
Altitude (M)	<2000
Storage temperature range (°C)	-20 to +60
Noise emission (dB)	<30
Overvoltage category	DC II ;AC III
Dimensions and Weight	
Dimensions (W*H*D) (mm)	516 (W) *525.6 (H) *151.7 (D)

Weight (kg)	28
Cooling concept	Natural-cooling
Isolation type	Transformerless
Communication	Wi-Fi, GPRS (Optional) , RS485
Display	LED
Warranty (Years)	5

Notes: “ * ” South African grid connection standard 4600w